



Industry & Invention
Patent

Utility Patents: Claim Construction and Infringement

Eric E. Johnson
ericejohnson.com



Konomark
Most rights sharable

I claim:

'444 Patent

1. An article for sitting
comprising:

- a bottom portion adapted for receiving the buttocks and thighs of a user,
- a back portion adapted for receiving the back of said user,
- a plurality of supporting legs attached to said bottom portion, and
- a means for securing and supporting said back portion to said bottom portion.

'444 Patent

I claim:

2. An article according to claim 1 wherein:

said bottom portion additionally comprises cushioning means for receiving the buttocks and thighs of a user.

'444 Patent

I claim:

1. An article for sitting comprising:

a bottom portion adapted for receiving the buttocks and thighs of a user,
a back portion adapted for receiving the back of said user,
a plurality of supporting legs attached to said bottom portion, and
a means for securing and supporting said back portion to said bottom portion.



I claim:

2. An article according to claim 1 wherein:

said bottom portion additionally comprises cushioning means for receiving the buttocks and thighs of a user.

'444 Patent

Accused product
Infringing?



I claim:

1. An article for sitting comprising:

a bottom portion adapted for receiving the buttocks and thighs of a user,
a back portion adapted for receiving the back of said user,
a plurality of supporting legs attached to said bottom portion, and
a means for securing and supporting said back portion to said bottom portion.

'444 Patent

Accused product
Infringing?



I claim:

2. An article according to claim 1 wherein:

said bottom portion additionally comprises cushioning means for receiving the buttocks and thighs of a user.

'444 Patent



I claim:

1. An article for sitting comprising:

a bottom portion adapted for receiving the buttocks and thighs of a user,
a back portion adapted for receiving the back of said user,
a plurality of supporting legs attached to said bottom portion, and
a means for securing and supporting said back portion to said bottom portion.

'444 Patent



'444 Patent

I claim:

1. An article for sitting comprising:

- a bottom portion adapted for receiving the buttocks and thighs of a user,
- a back portion adapted for receiving the back of said user,
- a plurality of supporting legs attached to said bottom portion, and
- a means for securing and supporting said back portion to said bottom portion.



What if this is revealed to have been on sale and publicly used a couple of years prior to the filing date of the '444 Patent?

- A. Claims 1 and 2 are still valid
- B. Claim 1 is valid, 2 is invalid
- C. Claim 2 is valid, 1 is invalid
- D. Claims 1 and 2 are invalid

'444 Patent

Prior art



'444 Patent

What is this is revealed to have been on sale and publicly used prior to the filing date of the '444 Patent?

- A. Claims 1 and 2 are still valid
- B. Claim 1 is valid, 2 is invalid
- C. Claim 2 is valid, 1 is invalid
- D. Claims 1 and 2 are invalid

Prior art



Okay, forget about that being prior art. Let's say that didn't happen ...

Let's add a new patent to the mix.

I claim:

'888 Patent

1. An article for sitting comprising:
 - a bottom portion adapted for receiving the buttocks and thighs of a user,
 - a back portion adapted for receiving the back of said user,
 - a plurality of legs attached to said bottom portion,
 - a means for securing and supporting said back portion to said bottom portion, and
 - [a swiveling means for rotating said bottom portion in an approximate plane to said floor.](#)

'888 Patent

I claim:

1. An article for sitting comprising:
 - a bottom portion adapted for receiving the buttocks and thighs of a user,
 - a back portion adapted for receiving the back of said user,
 - a plurality of legs attached to said bottom portion,
 - a means for securing and supporting said back portion to said bottom portion, and
 - [a swiveling means for rotating said bottom portion in an approximate plane to said floor.](#)



'888 Patent

I claim:

1. An article for sitting comprising:
 - a bottom portion adapted for receiving the buttocks and thighs of a user,
 - a back portion adapted for receiving the back of said user,
 - a plurality of legs attached to said bottom portion,
 - a means for securing and supporting said back portion to said bottom portion, and
 - [a swiveling means for rotating said bottom portion in an approximate plane to said floor.](#)



'888 Patent

Assume the '444 and '888 patents are both in force, both valid, both owned by distinct owners, and that there are no licenses. Does the owner of the '888 Patent have the legal entitlement to make and sell this chair?

- A. Yes
- B. No

Here we'll assume that a court determined the spoke-like structures with wheels are "legs" and that these legs are "attached" to the bottom portion and thus this chair reads on all elements of Claim 1 of the '444 patent.



'888 Patent

Assume the '444 and '888 patents are both in force, both valid, both owned by distinct owners, and that there are no licenses. Does the owner of the '888 Patent have the legal entitlement to make and sell this chair?

- A. Yes
 - B. No
- Why not?*



'888 Patent

Assume the '444 and '888 patents are both in force, both valid, both owned by distinct owners, and that there are no licenses. Does the owner of the '888 Patent have the legal entitlement to make and sell this chair?

A. Yes

B. No

Why not? The owner of the '888 would be infringing the '444. A patent only gives you the right to exclude others. It doesn't give the affirmative right to do anything with your invention.



'888 Patent

Assume the '444 and '888 patents are both in force, both valid, both owned by distinct owners, and that there are no licenses. Does the owner of the '888 Patent have the legal entitlement to make and sell this chair?

A. Yes

B. No

Why not? The owner of the '888 would be infringing the '444. A patent only gives you the right to exclude others. It doesn't give the affirmative right to do anything with your invention.

This situation is commonly referred to as "blocking patents." Neither patentee can make or sell the improvement without a license from the other.





from U.S. Pat. 4,239,129

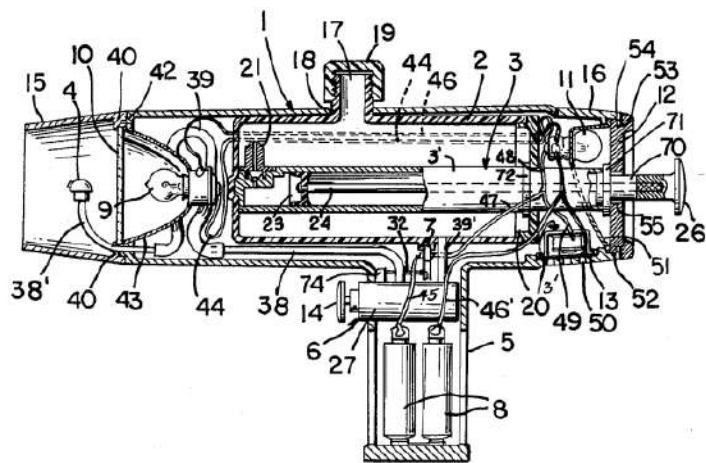

Larami v. Amron re U.S. Pat. 4,239,129

[Plaintiff] claims that SUPER SOAKER 20 literally infringes claim 1 of the '129 patent. Claim 1 describes the water gun as:

[a] toy comprising an elongated housing [case] having a chamber therein for a liquid [tank], a pump including a piston having an exposed rod [piston rod] and extending rearwardly of said toy facilitating manual operation for building up an appreciable amount of pressure in said chamber for ejecting a stream of liquid therefrom an appreciable distance substantially forwardly of said toy, and means for controlling the ejection.



Does the Super Soaker 20 infringe?

Held: No infringement. The Super Soaker 20 has the water tank outside the housing (not "therein"), so this accused product does not infringe Claim 1 of the '129 Patent.